

OTHER PRODUCTS

VDB30

VME 16x16 Video Routing Switcher

The VDB30 is a compact, VMEbus 16 x 16 video routing switcher, for use in either composite or component video systems. The highly flexible conduction cooled Double Euro board is designed to be hosted in a VMEbus card frame.

The VDB30 is used to provide 16 video outputs, which can be independently programmed to select any of the 16 video input signals and 8 TTL outputs, which can be independently programmed to select any of the 8 TTL input signals.

- **16 x 16 video routing switcher for use with composite sync video systems.**
- **8 YC x 8 YC video routing switcher, for use with YC video systems.**
- **4 RGB x 4 RGB video routing switcher, for use with composite synchs on green video systems, and a 4 x 4 video routing switcher for use with composite sync video systems.**
- **4 RGB x 4 RGB video routing switcher, for use with separate TTL synchs video systems, using separate TTL routing switcher, (VGA Systems), and a 4 x 4 video routing switcher for use with composite sync video systems.**
- **4 RGB + Sync x 4 RGB + Sync video routing switcher, for use with video systems with synchs on a separate video level channel.**
- **Any combination of the above.**

Due to the large number of pinouts required for this switching function the VDB30 has 3 variants:

VDB30: This has a non VME compatible P2 connector. A separate ± 5 volt analogue power supply is required. All switching options are available on the P2 connector.

VDB30 VME: This has a fully VME compatible P2 connector. All video switching options are available on the P2 connector. No TTL switching available. No Bitstream video overlay available. Single +5 volt power supply.

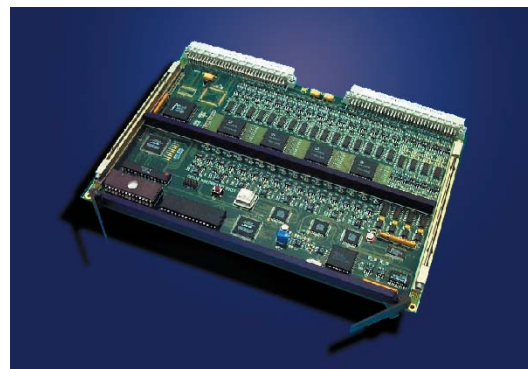

VDB30 VME P0: This has a fully VME compatible P2 connector. All video switching options are available on the P2 connector. All TTL switching options are available on the P0 connector. All Bitstream video overlay options are available on the P0 connector. Single +5 volt power supply.

Video

Each of the 16 video inputs is comprised of a balanced differential input followed by a DC restoration and buffer stage. Each of the 16 outputs includes an output amplifier which provides gain and response correction.

Text/Graphics Overlay

Each Video Out Channel has a multiplexer for Text/Graphics overlay, which can display data supplied from up to four Bit Stream inputs. The Bit Stream inputs must be synchronised with the video on which they are overlaid. Each Video Out channel can display a single line of 80 ASCII characters, programmed via the VMEbus or the Serial Link.

Control

The VDB30 is micro-processor controlled allowing the board to be controlled from the VMEbus or alternatively from a serial interface, configurable, via Internal Links, as follows: Electrical: RS232 or RS485 (2 wire) or RS485/422 (4 wire). The serial link is Factory configured for 9600 Baud, 8 Bits, 1 Stop Bit, Odd Parity.

VDB30 SPECIFICATIONS

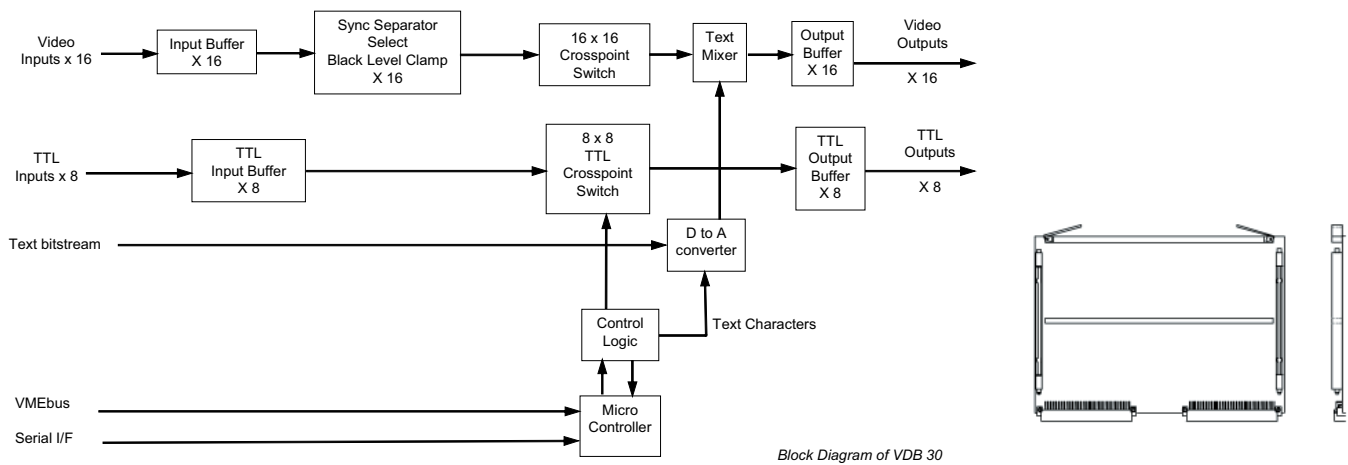

Block Diagram of VDB 30

Electrical Interface

Inputs

- Composite Video: 16 (Composite color or monochrome)
- TTL: 8

Outputs

- Composite Video: 16 (Composite color or monochrome)
- TTL: 8

Video Signals

- Video signal bandwidth is typically from DC to >25MHz at -3dB, assuming valid Sync signals are present.
- VDB30 accepts the following video standards:
 - Monochrome STANAG 3350 Class B or C
 - Color RGB STANAG 3350 Class B or C
 - Color Y/C
 - CCIR PAL
 - RS170/NTSC
 - Color RGB VGA

In general this implies the Video Distribution Board will tolerate the following:

- Lines: 525/625 /600
- Field Rate: 50/60Hz
- Interlace: 1:1 or 2:1
- Peak-Peak Voltage: 1V
- Sync Voltage: 0.3V
- Impedance: 75 Ohm

Video Signal to Noise

- Overall SNR: < -49dB
- Self Induced SNR: < -50dB
- Crosstalk SNR: < -55dB

Power Requirements

- VDB30:
 - +5 Volt Digital < 700mA
 - +5 Volt Analogue < 400mA
 - -5 Volt Analogue < 400mA
- VDB30 VME: +5 Volt < 1A
- VDB30 VME P0: +5 Volt < 1A

Mechanical

- Board Size: 233.4mm x 160.0mm (Double Euro)
- Width: 4HP (1 Slot)
- Connectors: 2 x 96 Way DIN41612 Plugs (VMEbus J1 and J2)

Operating Environment

- Temp. Range (operating): -5°C to + 50°C
- Cooling: Conduction Cooled
- R H: 5% to 95% non-condensing
- Shock (operational): 6g half sine wave for 11 ms in 3 axis

Octec has over 300 man years of experience in applied image processing and is one of the leading independent suppliers of 'commercial-off-the-shelf' video tracking and image processing systems to the global aerospace market. Part of Radstone Technology's Embedded Computing business, virtually every major European and US aerospace prime contractors is an Octec customer.

Octec's engineering expertise encompasses not only the hardware and software design of video trackers and image processing elements, but how they are applied to provide new or improved system capabilities. Octec also possesses great expertise in a wide range of complimentary technologies. These include system management processing, digital and analog interfacing and signal distribution as well as electro-optical sensor and overall systems integration for applications in the airborne, land and marine environments.



Octec Limited
The Western Centre
Western Road
Bracknell RG12 1RW
England

Tel: +44 1344 465 200
Fax: +44 1344 465 201
Email: sales@octec.co.uk

Octec US West office
14275 Parkside Court
Chino Hills, CA 91709
USA

Tel: 909 627 4816
Fax: 626 608 3511
Email: sales@octec.com